

SOIL PROPERTIES:

Permeability



Introduction

The permeability of a soil is a measure of the ability of soil to allow water to pass through it. It is typically represented by the letter 'k' and is measured as the volume of water (m^3) that can pass through an area (m^2) per second ($m^3/m^2/s$, or more simply m/s).

Factors Affecting Soil Permeability

The permeability of a soil is related most closely to its porosity (i.e. the gaps between the soil particles) but the shape of the pores and how they are (or are not) connected to one another also influences permeability. In natural soils, soil layering can also have a significant influence. As layers of soil are built up over time by various geological processes it is common for stratified soils (soils deposited in layers) to have much higher permeability in the horizontal direction than vertically, sometimes by a factor 10 or more. This means that water may flow horizontally through soil faster than it flows vertically.

Measuring Soil Permeability

Soil permeability can be measured in the laboratory using the methods described in Chapter 5 of BS 1377-5:1990, or BS 1377-6:1990. On site the method of testing is essentially to fill a hole with water and time how long it takes to drain away using methods defined in BS 5930:2015, BRE DG 365, or NHBC: Chapter 5.3. For soils placed and compacted on site, such as roading gravel or low permeability clay at the base of a pond, the lab tests are usually the most practical option. When measuring the permeability of soil on site the test should be conducted in-situ as samples taken from site to the lab may become disturbed and behave differently.

Typical Soil Permeabilities

As soils are so varied it is very difficult to give precise values for the permeability of a given soil without undertaking site specific tests. In the absence of site specific tests ABG typically uses the Handbook of Geotechnical Investigation & Design Tables (Look, 2007). This information has been combined into Table 1, below, which includes equivalent rainfall rates to allow a better understanding of the sort of water flow rates that the various values of permeability correspond to.



Figure 1: Stratified Soil

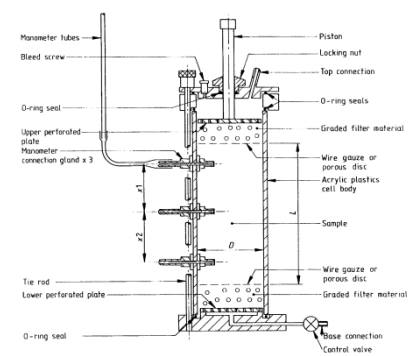

Figure 2: Soil Permeability Testing in accordance with BS 1377-5:1990

SOIL PROPERTIES:

Permeability



Table 1: Typical Permeabilities of Soils

Soil Type	Description	Permeability (k) (equivalent rainfall rate)	Suitability
Cobbles and boulders	Permeability may be greater as flow may be turbulent	1 m/s	Excellent
Gravels	Uniformly graded coarse aggregate with zero fines and minimal sand	10^{-1} to 10^{-2} m/s (>3600 mm/hr)	Very Good
Gravel sand mixtures	Clean, well graded, with minimal fines (e.g. crushed stone or 'Type 3' road aggregate)	10^{-3} to 10^{-4} m/s (3600 to 360 mm/hr)	Good
Clean Sands	Sands with low silt or clay content	10^{-4} to 10^{-6} m/s (360 to 3.6 mm/hr)	Good to moderate
Silt mixtures	Mixtures of sand, silt and clay (topsoil is typically in this category)	10^{-6} to 10^{-10} m/s (<3.6 mm/hr)	Moderate to poor
Clays	Pure clays	10^{-10} to 10^{-12}	Practically Impermeable
Artificial	Bituminous mixtures, cement stabilised soil, geosynthetic liners	$<10^{-12}$	

Technical Note

References

- British Standards Institution, BS 1377-5:1990 – *Methods of test for soils for civil engineering purposes. Compressibility, permeability and durability tests*
- British Standards Institution, BS 1377-6:1990 - *Methods of test for soils for civil engineering purposes. Consolidation and permeability tests in hydraulic cells and with pore pressure measurement*
- British Standards Institution, BS 5930:2015 - *Code of practice for ground investigations*
- Building Research Establishment. *Soakaway Design*. BRE DG 365. Bracknell, IHS BRE Press, 2016
- Look, B. (2007). *Handbook of geotechnical investigation and design tables*. London: Taylor & Francis.
- National House Building Council. *Drainage Below Ground*. NHBC Chapter 5.3. 2020